



LLENADO DE AUTOMÓVILES



DISPENSADORES



BOMBAS



MEDIDORES



MEDIDORES PARA PISTOLA



PISTOLAS

PIUSIBOX CAR SUCTION

CARACTERÍSTICAS

- IDEAL PARA VACIAR DEPÓSITOS DE VEHÍCULOS
- EVITA QUE EL DEPÓSITO SE LLENE EXCESIVAMENTE
- BOMBA DE MEMBRANA SUZZARABLUE
- FÁCIL DE MANIPULAR

PIUSI BOX Car Suction es la solución perfecta para quienes necesitan vaciar el depósito de AdBlue® de un vehículo antes de realizar tareas de mantenimiento. Incluye una caja portátil que contiene todo el equipo necesario.

RENDIMIENTO

hasta

34 L/MIN

CAUDAL

alimentación

CA

TENSIÓN

MÁX.

2M

límite

LONGITUD MANGUERA



PIUSIBOX CAR SUCTION



EMBALAJE

CÓDIGO	PESO		EMBALAJE		
	KG	LBS	MM	PULGADAS	UDS. /CAJA
FO0201R20	11,5	25,3	650X400X450	25,6X15,7X17,7	1



FILTRADO



SUPERVISIÓN DE LÍQUIDOS



ENROLLADORES DE MANGUERA



ACCESORIOS



ARTÍCULOS PROMOCIONALES

PIUSI

INDEX



CONEXIÓN DE AIRE



ANTI-CONGELANTE



AdBlue®



BIODIÉSEL



GASÓLEO



ALIMENTOS



GASOLINA



GRASA



QUEROSENO



ACEITE



AGUA



LIMPIA-PARABRISAS

CARACTERÍSTICAS CLAVE

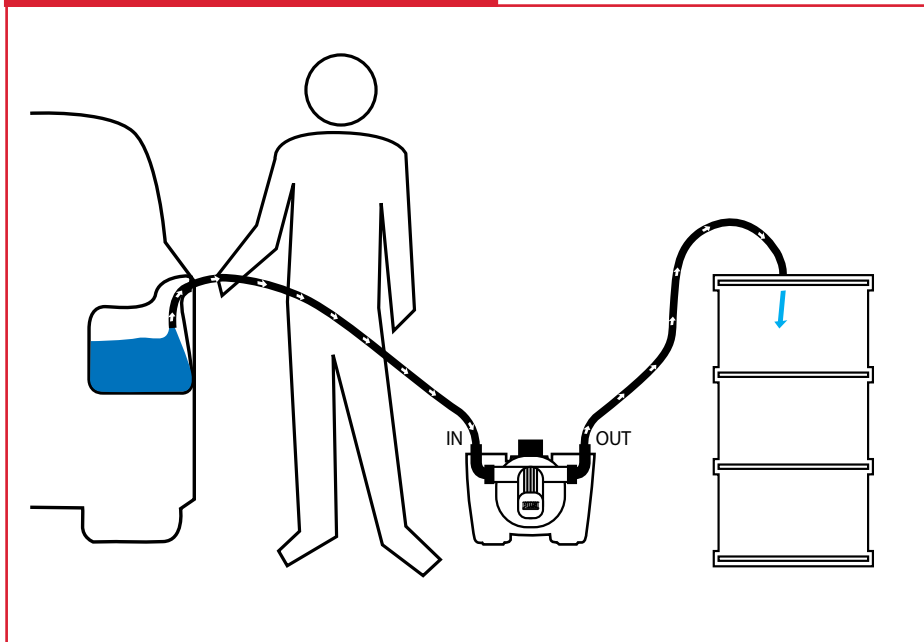

CONTENIDO DE LA CAJA

- BOMBA SUZZARABLUÉ
- MANGUERA DE SUCCIÓN / SUMINISTRO
- MANUAL DE INSTRUCCIONES

DETALLES



BOMBA SUZZARABLUÉ AC



INTERRUPTOR ON/OFF



MANGO

DIMENSIONES

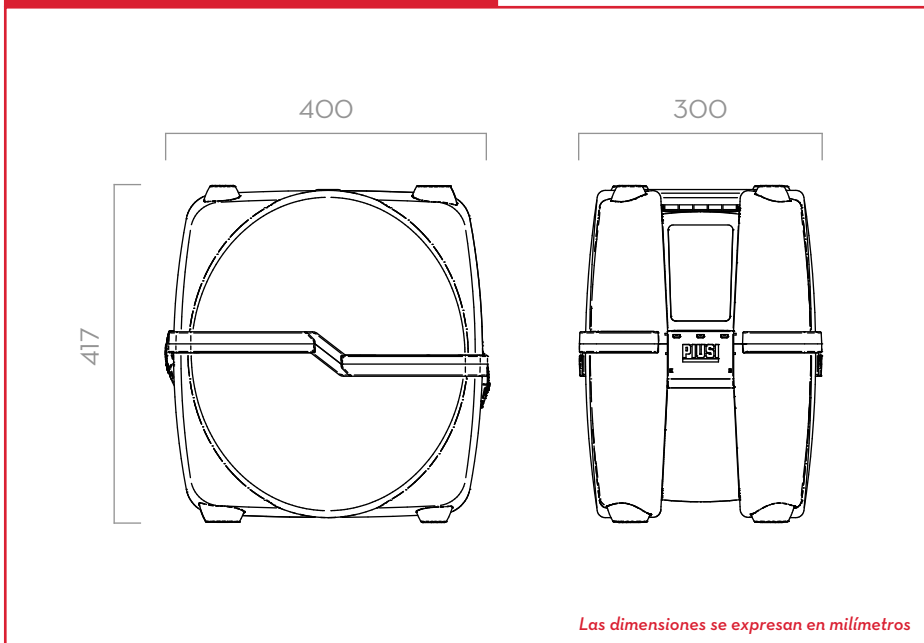

Las dimensiones se expresan en milímetros

MATERIALES

- CUERPO: POLIPROPILENO
- MEMBRANA: POLIPROPILENO

FICHA TÉCNICA

CÓDIGO	DESCRIPCIÓN	TIPO DE FLUIDO	CAUDAL		TENSIÓN			RPM	CICLO DE SERVICIO	CABLE	MANGUERA DE SUCCIÓN DE 12 MM Ø	MANGUERA DE 12 MM Ø
			L/MIN	GPM	V CA/HZ V CC	POTENCIA VATIOS	AMP. MÁX.				RPM	MIN
FOO201R20	PIUSIBOX CAR SUCTION ADBLUE		34	9	230/50	400	1,95	1450	20	SI	2	2 M

PIUSIBOX CAR SUCTION